



TAKAPUNA BOATING CLUB INC.
Takapuna Ocean Paddlers | Takapuna SUP | Taniwha Outrigger Canoe Club Inc.



the boat the world sails

2021 470 Class New Zealand National Championship 6-8 February 2021

The Organising Authority is Takapuna Boating Club Inc

SAILING INSTRUCTIONS

NB: The notation '[DP]' in a rule in the SI means that the penalty for a breach of that rule may, at the discretion of the protest committee, be less than disqualification.

1 RULES

- 1.1** The regatta will be governed by the rules as defined in *The Racing Rules of Sailing*.
- 1.2** The Yachting New Zealand Safety Regulations Part 1 shall apply.
- 1.3** Appendix T, *Arbitration*, will apply.

2 NOTICES TO COMPETITORS

Notices to competitors will be posted on the official notice board(s) located at the middle floor of Takapuna Boating Club.

3 CHANGES TO SAILING INSTRUCTIONS

Any change to the sailing instructions will be posted before 0900 on the day it will take effect, except that any change to the schedule of races will be posted by 2000 on the day before it will take effect.

4 SIGNALS MADE ASHORE

- 4.1** Signals made ashore will be displayed at a flag pole on the south east corner of the club.
A boat shall not go afloat until flag D is displayed ashore. The warning signal will not

5 SCHEDULE OF RACES/CLASS FLAGS

- 5.1** Schedule of Racing:

Day/Date:	Class:	Class Flag:	No of Races:	Time of First Warning Signal:
6 Feb	470	470	4	11.00
7 Feb	470	470	4	11.00
8 Feb	470	470	4	11.00

One extra race per day may be sailed, provided that no class becomes more than one race ahead of schedule and the change is made according to SI 3.

- 5.2 To alert boats that a race or sequence of races will begin soon, the orange starting line flag will be displayed with one sound at least five minutes before a warning signal is made.
- 5.3 On the last scheduled day of racing no warning signal will be made after 15.00 hrs.
- 5.4 The Race Area will be on the waters adjacent to Takapuna Beach.

6 THE COURSES

- 6.1 The diagrams in Attachments A and B show the courses, including the approximate angles between legs, the order in which marks are to be passed, and the side on which each mark is to be left.
- 6.2 No later than the warning signal, the race committee signal vessel will display the approximate compass bearing of the first leg.
- 6.3 Courses will not be shortened. This changes RRS 32.

7 MARKS

- 7.1 Marks are described in Attachments A and B
- 7.2 A race committee vessel signalling a change of a leg of the course is a mark as provided in SI 10.2.

8 AREAS THAT ARE OBSTRUCTIONS

The following areas are designated as obstructions:

- 8.1 The area adjacent to Takapuna Beach is a prohibited anchoring area. This area is shown in Attachment C.
- 8.2 Moving prohibited zone around vessels over 500 gross tonnage (Auckland Harbour Navigation and Safety Bylaws Section 55.

(1) A moving prohibited zone extending to 100 metres astern and 100 metres to each side of a large vessel, and continuing at such width to 500 metres ahead, following the line of the buoyed channel when changing course, is reserved around a large vessel, when that large vessel is underway within the pilotage areas of Auckland (excluding Tāmaki River) and Manukau.

(2) When navigating within a marked channel, the moving prohibited zone to the side of the large vessel is reduced to the width of the marked channel and the zone ahead of the large vessel must follow the line of the marked channel.

(3) The owner or person in charge of a vessel must not navigate the vessel within the moving prohibited zone of a large vessel, within the pilotage area of Auckland (excluding Tāmaki River) and Manukau.

(4) For the purpose of this clause, a tug and barge is considered a composite unit.

9 STARTS

- 9.1 The starting line will be between a staff displaying an orange flag on the starting mark at the starboard end and the course side of the port-end starting mark.
- 9.2 Boats whose warning signal has not been made shall avoid the starting area during the starting sequence for other races. [DP]
- 9.3 A boat that does not start within four minutes after her starting signal will be scored Did Not Start without a hearing. This changes RRS A4 and A5.

10 CHANGE OF THE NEXT LEG OF THE COURSE

- 10.1 To change the next leg of the course, the race committee will move the original mark (or the finishing line) to a new position.
- 10.2 Except at a gate, boats shall pass between the race committee vessel signalling the change of the next leg and the nearby mark, leaving the mark to port and the race committee vessel to starboard. This changes RRS 28.

11 THE FINISH

The finishing line will be between a staff displaying a blue flag on the finishing mark at the port end and the course side of the starboard-end finishing mark.

12 PENALTY SYSTEMS

- 12.1 For the 470 class RRS 44.1, is changed so that the Two-Turns Penalty is replaced by the One-Turn Penalty.
- 12.2 Appendix P will apply.
- 12.3 If a boat is penalised under Appendix P2 after she has finished, she shall be given a scoring penalty of 10% without a hearing although her score will not be worse than the score for a DSQ.

13 TIME LIMITS AND TARGET TIMES

- 13.1 Time limits and target times are as follows:

<i>CLASS</i>	<i>TARGET TIME</i>	<i>FINISH WINDOW</i>	<i>TIME LIMIT</i>
470	40 Minutes	10 Minutes	60 Minutes

- 13.2 Boats failing to finish within the Finish Window after the first boat sails the course and finishes will be scored Did Not Finish without a hearing. This changes RRS 35, A4 and A5.

14 PROTESTS AND REQUESTS FOR REDRESS

- 14.1 Protest forms are available at the race office, located at the middle floor of the Takapuna Boating Club. Protests and requests for redress or reopening shall be delivered there within the appropriate time limit.
- 14.2 For each class, the protest time limit is 60 minutes after the last boat has finished the last race of the day or the race committee signals no more racing today, whichever is later.

- 14.3** Notices will be posted no later than 30 minutes after the protest time limit to inform competitors of hearings in which they are parties or named as witnesses. Hearings will be held in the protest room, located at the middle floor of the Takapuna Boating Club.
- 14.4** On the last scheduled day of racing a request for redress based on a protest committee decision shall be delivered
- (a) within the protest time limit if the requesting party was informed of the decision on the previous day;
 - (b) no later than 30 minutes after the party was informed of the decision on the day.

This changes RRS 62.2

15 SCORING

15.1

- a) When fewer than six races have been completed, a boat's series score will be the total of her race scores.
- b) When six or more races have been completed, a boat's series score will be the total of her race scores excluding her worst score.

16 SAFETY REGULATIONS

16.1 Boats not leaving the shore for a scheduled race shall promptly notify the race office.

16.2 Check –out and check –in ashore:

- a) Competitors shall individually check out before racing by personally signing the check-out sheets located adjacent to the side door on the middle floor of the clubhouse. [DP]
- b) Competitors shall individually check-in immediately on returning to shore after racing, no later than the protest time limit by signing the check-in sheets located adjacent to the side door on the middle floor of the clubhouse. [DP]

16.3 A boat retiring from racing shall notify the Race Committee before leaving the racing area, or if that is not possible, shall notify the Race Office as soon as possible after returning ashore. [DP]

16.4 Boats retiring from racing shall in accordance with SI 17.4 shall complete a retirement declaration form at the Race Office before the protest time limit. [DP]

17 REPLACEMENT OF CREW OR EQUIPMENT

17.1 Substitution of competitors will not be allowed without prior written approval of the race committee. [DP]

17.2 Substitution of damaged or lost equipment will not be allowed unless authorised by the race committee. Requests for substitution shall be made to the committee at the first reasonable opportunity. [DP]

18 OFFICIAL BOATS

Official boats will be marked as follows: Race committee vessels will display club burgees.

19 SUPPORT BOATS

- 19.1** Except when requested to participate in rescue operations, team leaders, coaches, and other support persons shall stay outside areas where boats are racing and are restricted to a 5 knot speed limit, from the time of the preparatory signal for the first start of a sequence of starts until all boats have finished or the race committee signals a postponement or abandonment of all races. The areas the boats are racing in is defined as the area inside the course and within 100 metres of any mark, lay line, starting line, finishing line or any area where any boat that is racing is sailing or may sail. [DP]
- 19.2** Attention is drawn the relevant local council bylaws regarding wearing of lifejackets and other restrictions.
- 19.3** When flag V (with a long sound signal) is displayed on a committee boat all support boats are requested to remain afloat and assist all sailors.
- 19.4** Support boats shall be marked with the sail number of the competitor(s) they are supporting. [DP]

20 PRIZES

Prizes will be given as follows:

New Zealand 470 National Champion

New Zealand 470 Women's National Champion

New Zealand 470 Mixed National Champion

21 INSURANCE

Each participating boat shall be insured with valid marine third-party liability insurance with a minimum cover of \$1,000,000 per incident or the equivalent. Certificate of insurance is to be presented on request.

22 DISCLAIMER OF LIABILITY

Competitors participate in the regatta entirely at their own risk. See RRS 4, Decision to Race. The organising authority will not accept any liability for material damage or personal injury or death sustained in conjunction with or prior to, during, or after the regatta.

Attachment A

Appendix A : 420/470 – Trapezoid with signal boat for start and finish

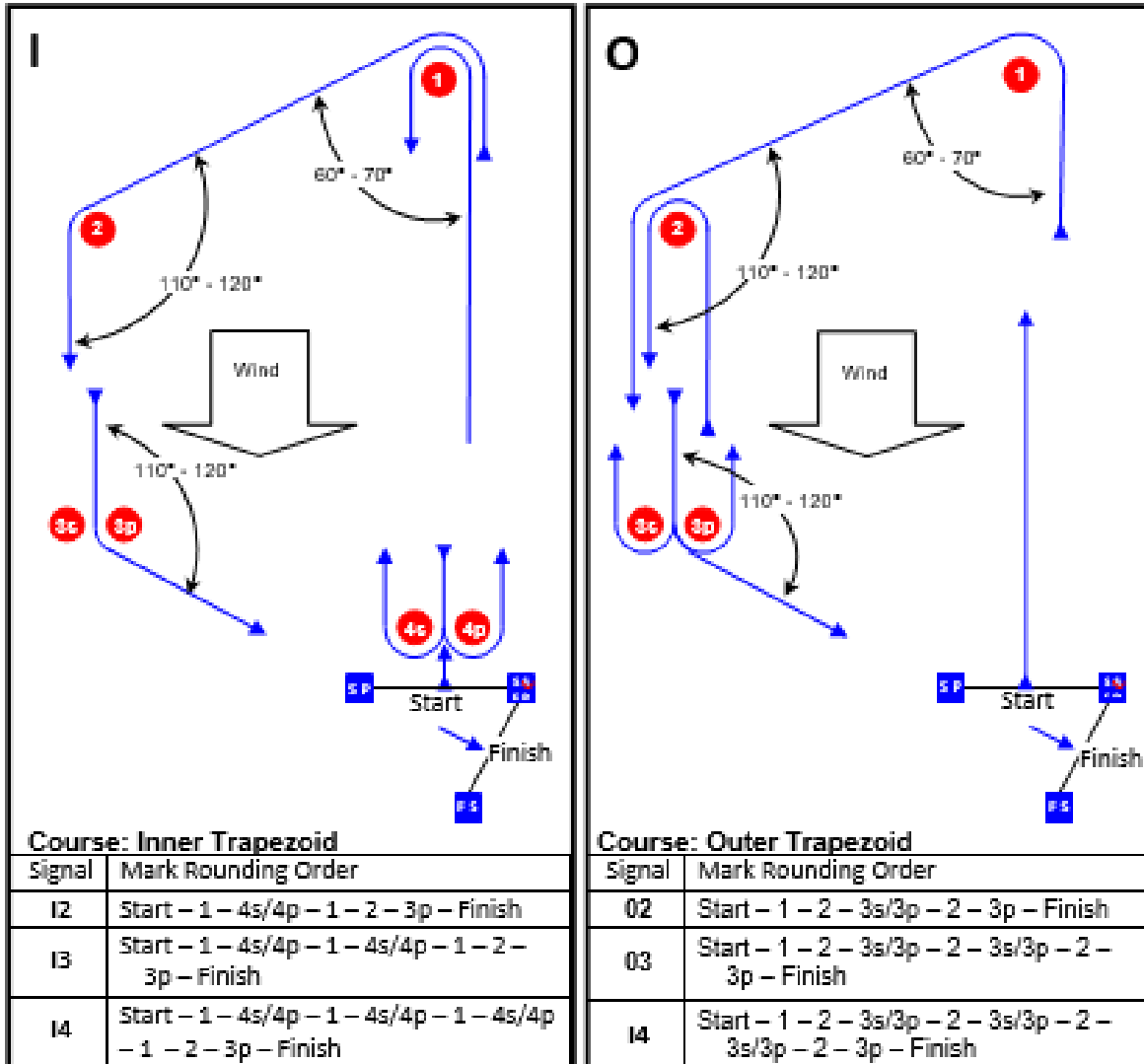

Mark	Description
1 2	Orange Spherical Buoy
3c 3p	Orange Cylindrical Buoy
4c 4p	Orange Cylindrical Buoy
SP Starting mark starboard end	Orange Flag on a staff
SP Starting mark port end	Orange Teardrop Buoy
FS Finishing mark starboard end	Orange Teardrop Buoy
FP Finishing mark port end	Blue Flag on a staff

Attachment B – Course Illustration Windward Leeward

L

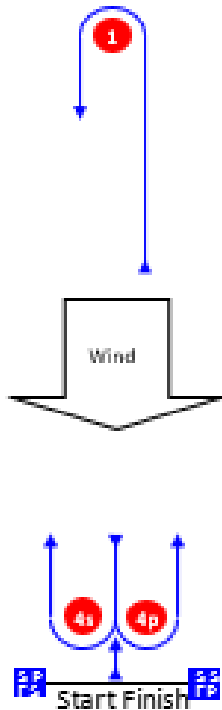

Course: Leeward finish

Signal	Mark Rounding Order
L2	Start – 1 – 4s/4p – 1 – Finish
L3	Start – 1 – 4s/4p – 1 – 4s/4p – 1 – Finish
L4	Start – 1 – 4s/4p – 1 – 4s/4p – 1 – 4s/4p – 1 – Finish

W

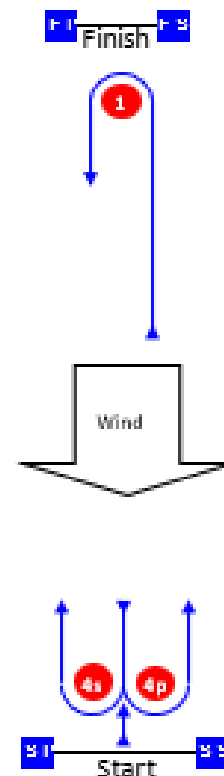

Course: Windward Finish

Signal	Mark Rounding Order
W2	Start – 1 – 4s/4p – Finish
W3	Start – 1 – 4s/4p – 1 – 4s/4p – Finish
W4	Start – 1 – 4s/4p – 1 – 4s/4p – 1 – 4s/4p – Finish

Mark	Description
1	Orange Cylindrical
4s 4p	Orange Cylindrical
S S Starting mark starboard end	Race committee vessel
S P Starting mark port end	Orange Teardrop
P S Finishing mark starboard end	Orange Teardrop
P P Finishing mark port end	Race committee vessel

Attachment C

Prohibited anchorage area.

